



Disc Diffuser
Technical Reference



Dimensions

Type	Height [mm]	Diameter total/effective [mm]	Overall height membrane top of tube [mm]	Perforated area [m ²]	Material of plastic base	Membrane- material	Total weight [kg]
HD 270	58	270 / 220	30	0,037	PP GF 30	EPDM/Silikon	0,6
HD 340	76	340 / 310	46	0,060	PP GF 30	EPDM	0,85
HD 235	45	240 / 209	32	0,030	PA GF30	EPDM	0,5
HD 325	45	330 / 290	32	0,059	PA GF30	EPDM	0,9
ECO 21	55	270(*) / 230	24	0,045	PP GF30	EPDM	0,7
ECO 34	55	270(*) / 230	24	0,045	PP GF30	EPDM	0,7

(*) without fastener ring

All diffusers are equipped with 3/4" NPT thread

Grommets for 3/4" NPT Threads

Type	Permitted wall thickness of header tube [mm]	Diameter of straight-drilled hole [mm]	Material	Colour
Grommet 4,7	4,7	31,8 (1 1/4")	EPDM 75 Sh A	Black
Grommet 6,3	6,3	31,8 (1 1/4")	EPDM 75 Sh A	Black
Universal Saddle	2 - 8	31,8 (1 1/4")	EPDM 75 Sh A	Black

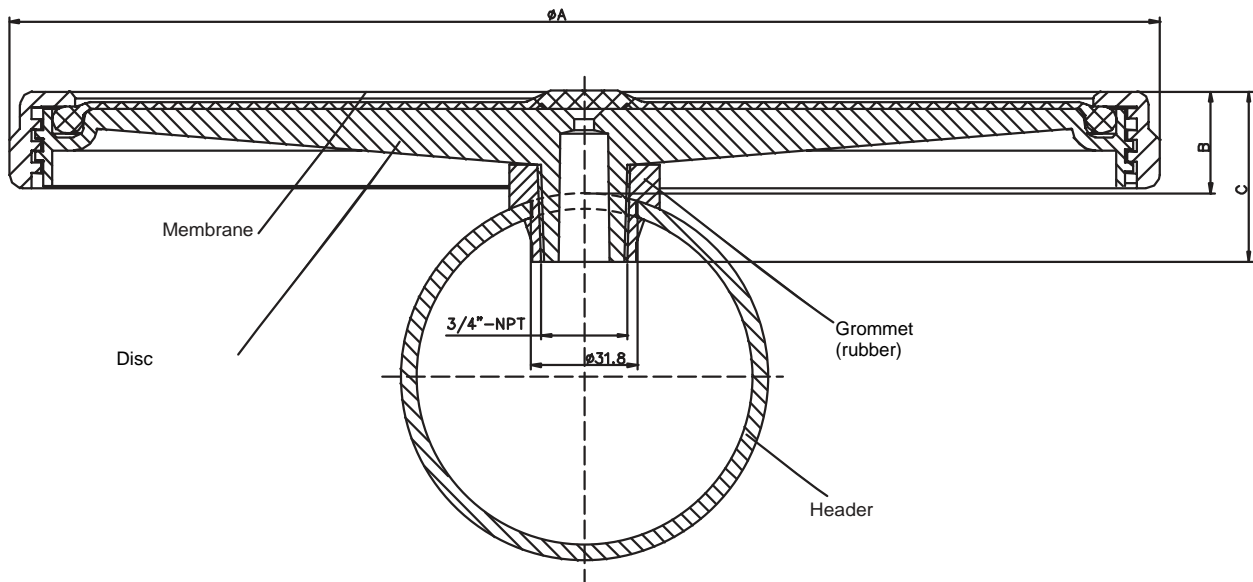

	HD 270	HD 340	HD 235	HD 325	ECO 21/34	
A	270	340	240	330	270	Diameter
B	30	46	32	32	24	Overall height Membrane-top of tube
C	60	76	45	45	55	Diffuser height

Only overall dimension, diffuser design does not correspond with drawing.

Air flow

Type	Air flow rates at standard operation conditions [m _N ³ /h]	Overload air flow rate [m _N ³ /h]
HD 270	1,5 - 7	10
HD 340	2 - 10	6
HD 235	1,5 - 7	12
HD 325	2 - 10	6
ECO 21	1,5 - 7	12
ECO 34	2 - 10	6

- Air flow rates depending on material, slit pattern etc.
- Other slit patterns on request
- Shutdown of operation is highly recommended for air flow rates lower than minimum rate.
- Overload air flow rate (e.g. cleaning) should not be applied longer than 10 min/day

Typical physical properties, measured on cured rubber membranes:

Membrane type	Standard EPDM	Low plasticiser EPDM	Silikon
Colour	Black	Black	Translucent
Wall thickness	2,0 mm ± 0,15 mm		1,5mm ± 0,2 mm
Density	DIN 53479 < 1,2 g/cm ³	< 1,1 g/cm ³	< 1,15 g/cm ³
Tensile strength	DIN 53504 > 7 N/mm ²	> 8 N/mm ²	> 8 N/mm ²
Elongation at break	DIN 53504 > 500%	> 500%	> 650%
Tear strength	DIN 53507 > 6 N/mm	> 8 N/mm	> 15 N/mm
Hardness	DIN 53505 50 ± 5 Shore A	57 ± 5 Shore A	60 ± 5 Shore A
Tension set	100% Elongation 24 h, RT < 5%	< 5%	----
Operation temperature range	0 bis 80°C	0 bis 80°C	5 bis 100°C
Applications	Municipal waste water facilities	Municipal and industrial waste water facilities	Industrial waste water facilities with high load of oils and process related deposits and/or fouling

Other speciality engineered materials are available on request.

Operation mode:

continuously or intermittent

Materials:

Different rubber components for the special requirements of various waste waters are available. The most common materials is EPDM, a kind of rubber that is used for a long time in lots of variants in municipal waste water treatment plants.

Also silicone rubber can be used for fine bubble diffusers. But silicone membranes are more sensitive to all mechanical movements. Because of this reason, we are using special silicone compounds and also special diffuser designs.

Furthermore, silicone is more expensive than EPDM, because of the material price.

For all these reasons, silicone membranes are a good alternative for the use in all waste waters which damage or destroy EPDM such as high concentrated grease, oil and hydrocarbons and should only be used there.

For all waste waters with middle and low concentrated grease and oil it is also possible to use EPDM with low plasticiser content. The normal content of plasticiser is appr. 30%. It can be reduced to 15% for EPDM sleeves and to 10% for disc membranes. This helps a lot to prevent diffuser damages by industrial waste water.

Oxygen Transfer efficiency and headloss Disc Diffuser HD 270, low plasticiser membrane (Other models upon request.)

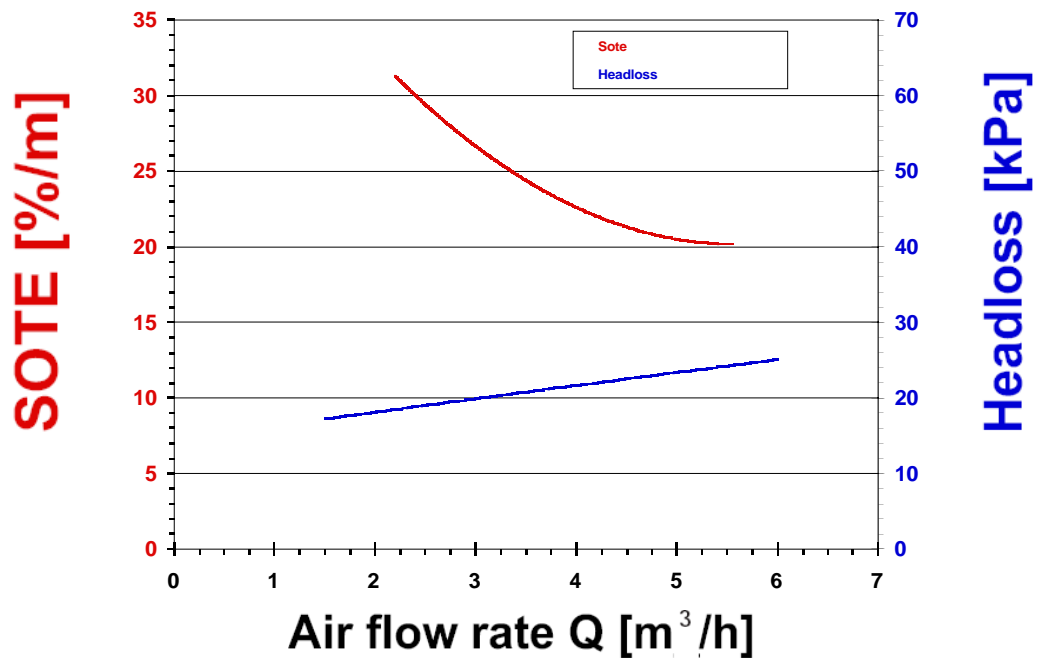

Results depending on tank size, diffuser disc, slit pattern, material, water depth etc.

Storage:

- Diffuser and/or rubber sleeves must be stored factory-packed in a dark, dry, ventilated and dust-free storage space according to DIN 7716. Avoid frost, heat, UV/Vis-radiation, dust and working which can cause damage of diffuser and/or packing.
- Do not store outdoors! The storage of rubber parts until installation/starting operation should not exceed one year. At on-site delivery all rubber and plastic parts must be stored in their original packaging. Crates exposed to direct sunlight must be covered with tarpaulin to protect against UV-radiation.

Cleaning:

Diffusers can only be checked, if the activated sludge tank is out of work and empty. That is why normal cleaning must be done at work. Formic acid is used very successfully against carbonating. To keep the pores open, formic acid is sprayed into the compressed air for a short time. Also a regular use with maximum air flow for a short time helps keep the diffuser in good conditions for a long time.

Membrane lifetime:

Up to 10 years in municipal waste water treatment plants, depending on waste water influent and operation condition.

BIBUS AG

Hertistrasse 1
CH-8304 Wallisellen
Tel. +41 44 877 51 20
Fax +41 44 877 58 51
E-Mail: info.bag@bibus.ch
www.bibus.ch

BIBUS GmbH

Lise-Meitner-Ring 13
DE-89231 Neu-Ulm
Tel. +49 731 20769 0
Fax +49 731 20769 620
E-Mail: info.bag@bibus.ch
www.bibus.de